

#### MEASURE FASTER THAN EVER

Our revolutionary SpinLaserTechnology™ reduces the time spent for measurement and alignment drastically.

Briefly described it works as this:

The laserbeam from the transmitter rotates constantly and “builds” a reference plane in space. Select your measurement points anywhere within the laser sector, place the detector and register the values. The result of the measurement can be displayed both digitally and graphically. It is easy to see how straight, flat or parallel the object is compared to selected reference points.

The system is perfect for measuring straightness, flatness, parallelism, dynamical movements as well as horizontal and vertical planes at:

- Machine tables
- Foundations
- Flanges
- Machine constructions
- Rolls etc.

If wanted you can also read measurement values live (dynamic measurement) with up to four detectors connected in series and at the same time to see how the object is bending/twisting at each measurement point, e.g. when doing the adjustment.

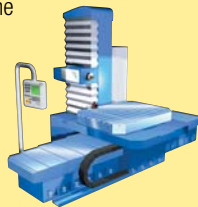
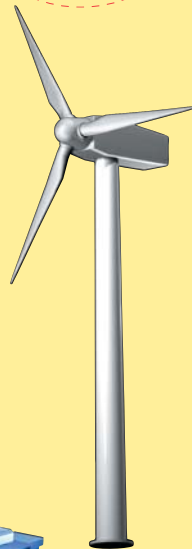
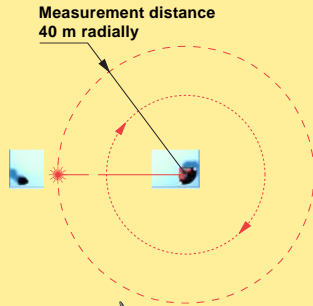

#### LASER TRANSMITTER AND DETECTOR

##### LASER TRANSMITTER D23

Battery operated laser transmitter with motor driven rotating head. Laser sector 360°. Measurement distance 40 m [130'] radially.

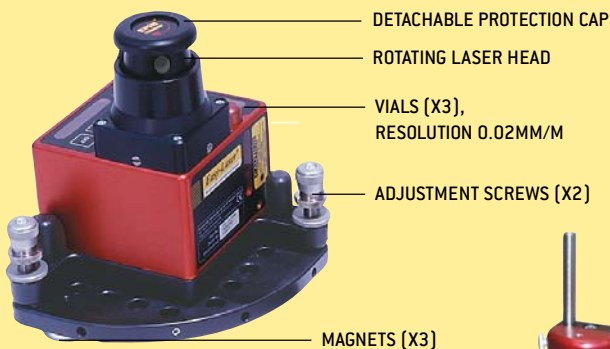

##### DETECTOR D6

1 axis PSD; aperture 18mm [3/4"]. Built-in inclinometer; resolution 0.1°.

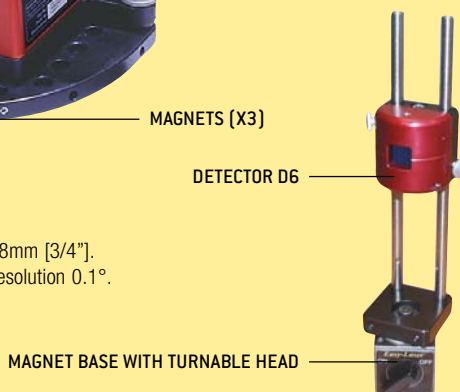

#### MEASUREMENT EXAMPLES

##### Flatness on flanges

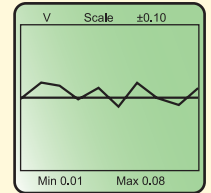
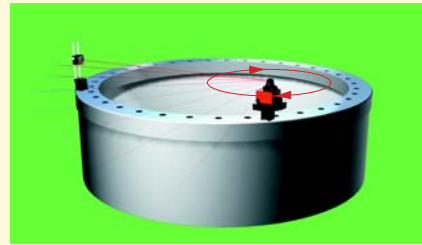

Displays flatness with 3 ref. points at 120° in between.

##### Flatness on machine tables

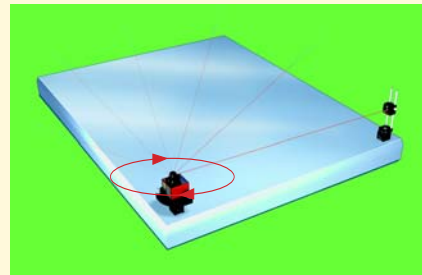

Ready:		V
X1 ,Y2	V	0.14
X2 ,Y2	V	0.47
X3 ,Y2	V	0.85
X4 ,Y2	V	0.64
X5 ,Y2	V	0.42
X1 ,Y3	V	0.13
X2 ,Y3	V	-0.06
X3 ,Y3	V	-0.22
X4 ,Y3	V	-0.25
X5 ,Y3	V	0.00

Ref. points  
1, 1    5, 1    5, 3

Displays flatness with 3 ref. points.

##### Plane parallelism on press tables

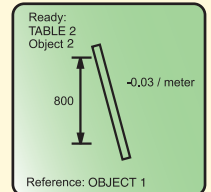
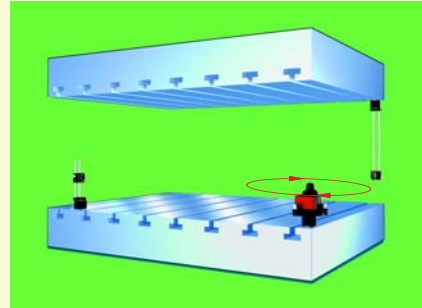

Displays parallel error between the press tables.

##### Plane parallelism and straightness on foundations

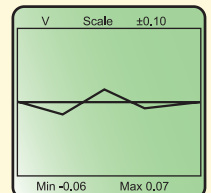
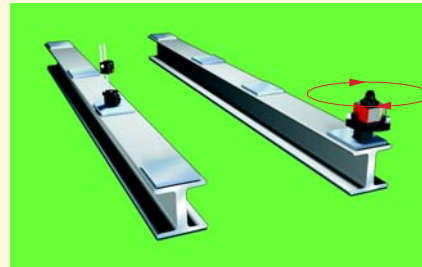

Displays straightness and parallelism with 2 ref. points.

##### Straightness and flatness on machine constructions

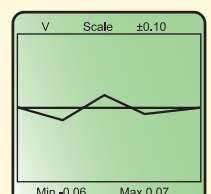
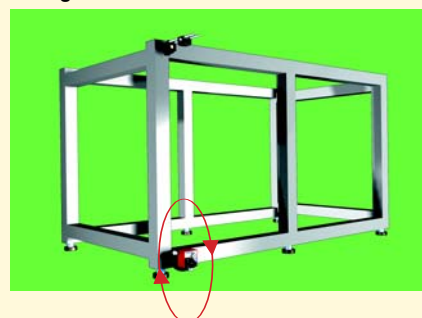

Displays straightness and flatness.



## THE MEASUREMENT PROGRAMS

The Display unit has all our programs included, of which 5 takes advantage of the SpinLaserTechnology™. As your measurement needs increase you can add suitable equipment. For detailed information, please see our other brochures.



Measurement programs for SpinLaserTechnology™ working with laser D23 and detector D6:

**STRAIGHTNESS** – Universal straightness program. Any measurement points can be used as references. Handles up to 150 measurement points with 2 arbitrary zero points.

**FLATNESS** – Universal flatness program. Handles up to 300 measurement points with 3 zero points.

**FLANGE** – For measurement of flatness on flanges and circular planes, for example axial bearings. Up to 150 measuring points can be handled. 3 zero points with 120° in between are calculated by the system.

**PARALLELISM** – For measuring between rolls, machine sides etc. Handles up to 150 rolls or other objects. Baseline or roll can be chosen as reference. Each measurement object is given a specific name.

**VALUES** – Shows values live from 1– 4 detectors connected in serie. The values can be zeroed individually. Suitable for dynamic measurements.

### Other measurement programs and functions included:

- |   |   |   |
|---|---|---|
| <b>SQUARENESS</b>                                   | <b>SPINDLE</b>  | <b>HALF CIRCLE</b><br>(straightness)              |
| <b>PLUMBLINE</b>                                    | <b>CENTER OF CIRCLE</b><br>(straightness)               | <b>HORIZONTAL</b><br>(shaft alignment)            |
| <b>BTA DIGITAL</b><br>(belt transmission alignment) | <b>EASY-TURN™</b><br>(shaft alignment)                  | <b>SOFTFOOT</b><br>(shaft alignment)              |
| <b>VERTICAL</b><br>(shaft alignment)                | <b>CARDAN</b><br>(shaft alignment)                      | <b>OFFSET AND ANGLE</b>                           |
| <b>MACHINE TRAIN</b><br>(shaft alignment)           | <b>THERMAL GROWTH COMPENSATION</b><br>(shaft alignment) | <b>REFLOCK™</b><br>(shaft alignment)              |
| <b>VIBROMETER</b><br>(vibration level and g-value)  | <b>TOLERANCE CHECK</b><br>(shaft alignment)             | <b>MEASUREMENT VALUE FILTER</b><br>(sub function) |

## DOCUMENTATION

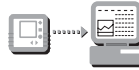

### SEND DATA TO PC

With the EasyLink™ Windows® program (included) you can make professional reports with both pictures and measurement data, export to spreadsheets like Excel® and try different settings of reference points to optimize your adjustment and tooling work.

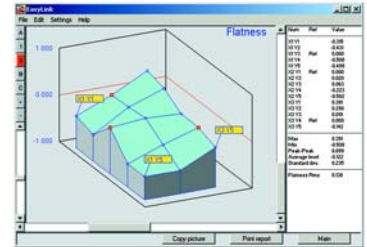
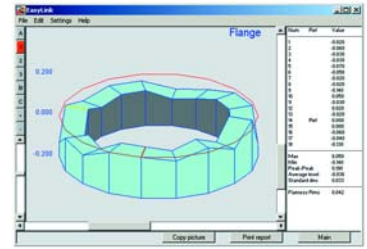

### MAKE A PRINTOUT

You get all measurement data on the printout for fast documentation.

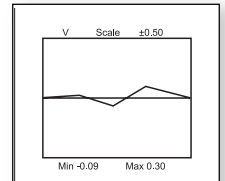

MEMORY MENU	
1	2003.01.27 17:14
2	2003.01.27 10:09
3	2003.01.26 11:34
4	2003.01.17 14:09



### STORE IN THE DISPLAY UNIT

You assign a specific name, then the system adds date and time automatically.

EASY LASER ALIGNMENT TOOLS				
COMPANY : .....				
MACHINE : .....				
OPERATOR : .....				
Date	:	1999.02.15	20:01	
Filename	:	Straightness		
Unit	:	mm		
Serial No	:	13636, 13633		
Temp	:	21.4		
No	Ref	Distance	V-values	H-values
1	Ref	0	0,00	0,00
2	100	0,01	0,00	
3	100	-0,09	-0,15	
4	100	0,30	0,09	
5	Ref	100	0,00	0,00
Max			0,30	0,09
Min			-0,09	-0,15

## EASY-LASER® D800 MACHINE

Part.Nr. 12-0220

- 1 Display unit D279
  - 1 Detector D6
  - 1 SpinLaserTransmitter D23
  - 2 Cables with Push/Pull-connection (2m, 5m)
  - 1 Magnet base (for laser transmitter)
  - 1 Magnet base (for detector)
  - 1 EasyLink™ Windows® program + PC cable
  - 1 Measuring tape
  - 1 Manual
  - 1 Leatherette
  - 1 Carrying case
- Accessories: Printer etc.*



Easy-Laser® is manufactured by Damalini AB, Åbäcksgatan 6B, 431 67 Mölndal, Sweden, Phone +46 31 18 87 70, Fax +46 31 18 87 75, email: info@damalini.se, www.damalini.com © 2004 Damalini AB. We reserve the right to make modifications without prior notification. Easy-Laser® is a registered trademark of Damalini AB. Windows® and Excel® are registered trademarks of the Microsoft Corporation.

Authorized dealer



This product complies with:  
SS-ENG0825-1-1994,  
21 CFR 1040.10 and 1040.11

